

# Installation Guidelines

## FOR REVIVE WOOD CLAD AND HYBRID POCKET REPLACEMENT WINDOWS

### Installer

- Read instructions completely before attempting installation. Failure to follow these guidelines will forfeit the Windsor warranty coverage, written or implied. Windsor Windows & Doors will not be held responsible for any claims or damages as a result of installation.
- Always provide a copy of these instructions to the homeowner.
- These instructions are consistent with ASTM 2112 “Standard Practice for Installation of Exterior Windows, Doors and Skylights” into common wall constructions. Contact your architect or construction professional for installation into other building designs or construction methods.
- Regional codes and environmental conditions may require installation that is different from these guidelines. It is your responsibility to ensure that local codes and ordinances are followed.

### Warning

- ⚠ **Work Safe!** Always wear proper eye and hearing protection when installing or adjusting Windsor products.
- ⚠ **Use Power Tools Properly!** To avoid personal injury, always follow manufacturers’ instructions for safe operation of power tools.
- ⚠ **Ladder Safety!** Working at elevated levels can be hazardous. Always use ladders and scaffolding properly. Consult manufacturers’ guidelines for safe use of these types of equipment.
- ⚠ **Safety Glazing!** Windsor products do not contain safety glazing unless specifically ordered that way. Use caution - injury could result if glass is broken and fragmented. Building codes require safety glazing for windows installed in certain areas. Consult your local building code official for guidelines.

### Handling and Storage

- **CAUTION: Prefinished Interiors:** Windows with prefinished interiors must be protected from dents, scratches, scrapes or other blemishes.

Windsor does not warrant against dents, scratches, scrapes or other damage to prefinished interiors after the Windsor products leave Windsor’s possession. After the Windsor products leave Windsor’s possession, extreme care must be taken by those working on or around the windows, to protect prefinished interiors from dents, scratches, scrapes or other blemishes.

### **IMPORTANT! IF VINYL WINDOWS AND DOORS ARE NOT INSTALLED IMMEDIATELY UPON DELIVERY, THEY MUST BE PROPERLY STORED AND PROTECTED UNTIL INSTALLED.**

If the vinyl product is not stored properly, distortion of the frames can occur affecting operation and performance. Vinyl windows and doors should be installed within 30-60 days of receiving.

### **IMPORTANT**

- **WARNING:** Use of Windsor products in barrier systems that lack a suitable exterior like siding, masonry, stucco, or EIFS with an engineered drainage system, will void all Windsor warranties, written or implied, and Windsor Windows & Doors will not be held responsible for any claims or damages resulting from the lack of a suitable exterior. The lack of a suitable exterior as described herein prevents application of proper perimeter sealant of the windows or door frame as required by Windsor’s Installation Guidelines. Exterior membranes, liquid applied and otherwise, DO NOT qualify as a suitable exterior.

### **Follow these procedures for proper storage of vinyl windows and doors:**

- **Remove stretch wrap immediately so the individual units can be exposed to circulated air.**
- **Do not store units outside or in direct sunlight. Allow sufficient spacing between products for ventilation.**

- **Never store vinyl units in a closed truck or other similar enclosure.**
- **Never stack or lean vinyl units against each other in the sun.**
- **Always carry vinyl units upright. Do not carry flat! Doing so can result in damage to the unit.**
- **Always store vinyl units vertically. Do not store windows flat or stack horizontally.**
- **Vinyl units must be stored in a clean, dry, well-ventilated area where they will be protected from the elements.**
- **Vinyl windows with unsupported nailing fins should have their corners blocked and protected to prevent damage to the nailing fin.**

**Failure to follow these procedures will void our product warranty.**

### Parts Included

- Replacement Window
- Frame Expander – Optional (Side and head)
- Installation Screws
- Interior Wood Sash Cover (DH picture window only)
- Side Stops with Insertion Barbs (Casement only)

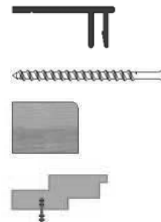

### Materials Needed

- 100% Silicone
- Exterior Grade Sealant
- Backer Rod – 1/4"-1/2" diameter closed cell foam
- Low-Expansion Foam
- Shims – Made of cedar or synthetic material

### Tools Needed

- Safety Glasses 
- Tape Measure 
- Level 
- Putty Knife 
- Mallet 
- Screwdriver (Phillips and Flat Head) 
- Power Drill 
- Reciprocating Saw 
- Silicone Application 

**ATTENTION! ARBITRATION AGREEMENT; JURY TRIAL WAIVER; CLASS ACTION WAIVER.** By purchasing, installing or using this product, you agree to arbitrate any dispute you may have with Windsor relating to your Windsor products, and to waive your rights to a jury trial and to participate in class-action or class-arbitration proceedings, relating to any such disputes. For more details, and to learn how **YOU CAN OPT OUT OF THIS ARBITRATION AGREEMENT AND THESE WAIVERS**, please go to [www.windsorwindows.com/support/Dispute-Resolution](http://www.windsorwindows.com/support/Dispute-Resolution).

### **LEAD PAINT AND EXISTING WINDOW DISPOSAL:**

- A) Before any remodel or renovation, make sure to identify any potential lead paint issues and take necessary steps to reduce the risk of lead contamination.
- B) The U.S. Environmental Protection Agency (EPA) has issued a “Lead Renovation, Repair and Painting Rule (RRP)” for remodelers of older homes and buildings. This rule requires training and certification in lead-safe work practices for firms performing renovation, repair or painting on homes and child-occupied facilities built prior to 1978.
- C) For more information regarding procedures for dealing with lead paint, please visit EPA’s website at [www.epa.gov/lead](http://www.epa.gov/lead).
- D) When removing existing windows, make sure to wear appropriate personal protective equipment. Extra precautions should be taken to protect others and property within the vicinity and below the removal window and surrounding components.
- E) Consult with local waste authorities on the proper recycling or disposal of old window components.

## **Step 1: Inspect Replacement Window**

- A) Unwrap replacement window.
- B) Verify window specification (product, size, color, grille pattern, etc.).
- C) Visually inspect window for physical or cosmetic damages.
- D) Verify included parts (listed to the left). **Note: Contact dealer or distributor for recommendations before installing if any part of the list is concerning.**

## **Step 2: Interior/Exterior Installation Preparation**

**IMPORTANT:** Installation preparation can be done from the interior or the exterior. Prior to beginning installation – verify the dimensions of the existing frame.

- A) Measure the opening width of the existing frame at the top, middle and bottom of the frame. (Fig. 1 & 2) Verify the replacement window frame width is approximately 1/2" smaller than the existing frame width.

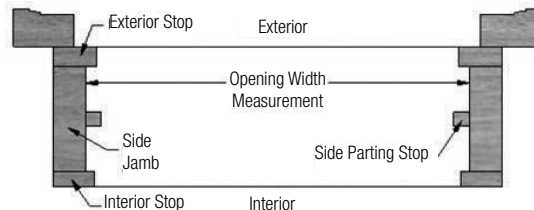

**FIG. 1**

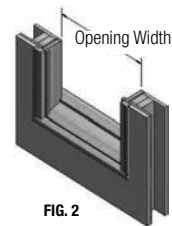

**FIG. 2**

- B) Measure the opening height of the existing frame at the left, right and center of the frame. (Fig. 3 & 4) Verify the replacement window frame height is approximately 3/8" smaller than the existing frame height. **Note: Measure from inside of head jamb to top of sill.** (Fig. 3 & 4)

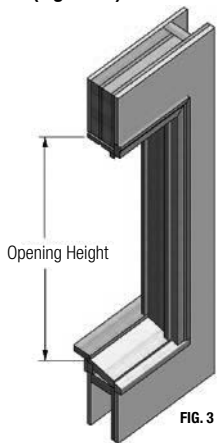

FIG. 3

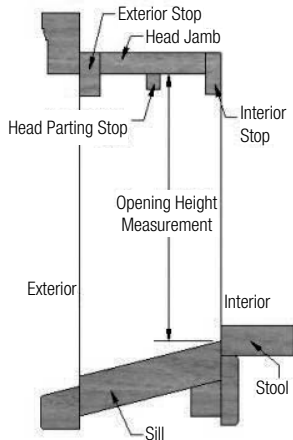

FIG. 4

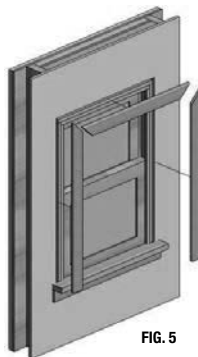

FIG. 5

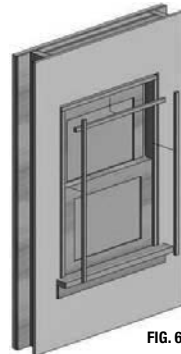

FIG. 6

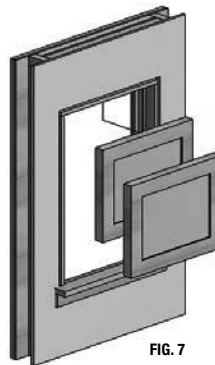

FIG. 7

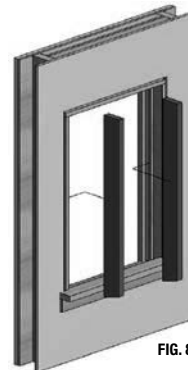

FIG. 8

## Step 2A: Interior Install Preparation

- A) If required, remove interior trim. If you plan to reuse interior trim, remove with caution. (Fig. 5)
- B) Remove interior stops from frame. If you plan to reuse interior stops, remove with caution. (Fig. 6)
- C) Remove existing sash from frame. (Fig. 7)
- D) Remove existing balance system (cut cords if necessary, detach pulleys). (Fig. 8) **A casement window would not have an existing balance system.**
- E) If applicable, remove parting stops from head and side jambs. (Fig. 9) **A casement window would not have parting stops.**
- F) Clean corners inside frame and along sill.
- G) Apply silicone to sill joints along side jamb and sill stop. (Fig. 10)
- H) Apply silicone to interior joints of the exterior stops along both side jambs and head jamb. (Fig. 11)



FIG. 9

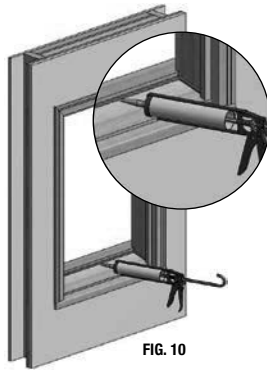

FIG. 10

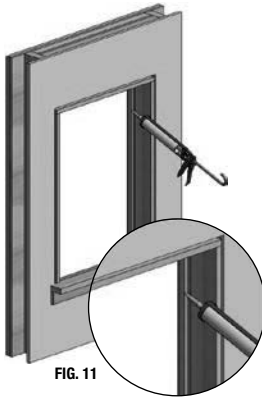

FIG. 11

## Step 2B: Exterior Install Preparation

- A) Remove exterior stops from head and side jambs of frame.  
A reciprocating saw may be necessary for removal. (Fig. 12 & 13)
- B) Remove existing sash from frame. (Fig. 14)
- C) Remove existing balance system (cut cords if necessary, detach pulleys). (Fig. 15) **A casement window would not have an existing balance system.**
- D) If applicable, remove parting stops from head and side jambs. (Fig.16) **A casement window would not have parting stops.**
- E) Clean corners inside frame and along sill.
- F) Apply silicone to the joints along the sill, side jamb and side sill stops. (Fig. 17)

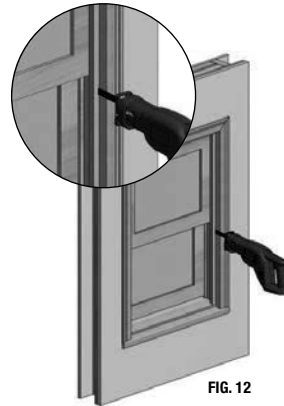

FIG. 12

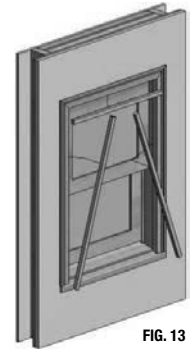

FIG. 13

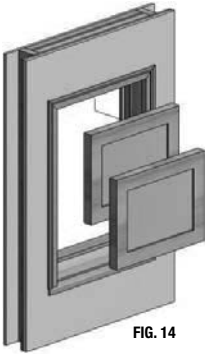

FIG. 14

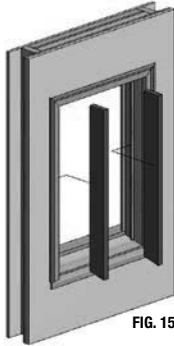

FIG. 15

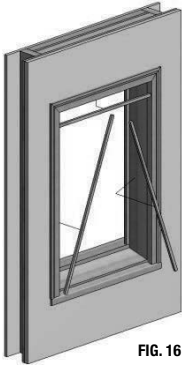

FIG. 16

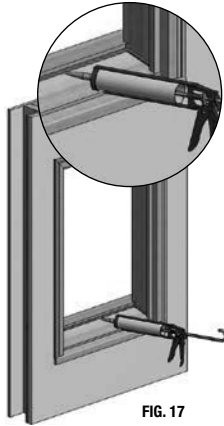

FIG. 17

## Step 3: Install Window

**IMPORTANT: Window installation can be done from the interior or the exterior.** Installation of replacement window should be completed by two or more people.

### Step 3A: Interior Install

- A) Tilt top of replacement window toward interior as shown. (Fig. 18 & 19)
  - Insert bottom of replacement window into existing frame so exterior side of replacement jamb is pressed up against current exterior stops.
  - Insert the top of replacement window.
- B) Appropriately shim the window to obtain a level and square window with uniform frame dimensions. (Fig. 20) **Note: Place a shim behind each installation screw hole and at the center on each side.**
- C) Apply installation screws in pre-drilled locations in each side jamb for double hung (Fig. 31) and casement. (Fig. 21)

#### Double hung:

- Apply each upper side screw within the interior balance channel. **Note: Ensure screw heads are flush with face of jambliner shell.**
- Raise the lower sash a minimum of six inches.
- Apply each lower side screw within the interior balance channel. **Note: Ensure screw heads are flush with face of jambliner shell.**

#### Casement:

- Apply four screws into the pre-drilled holes in the side jamb. **Note: Ensure screw heads are flush with face of the side jamb.**
  - Apply wood side stops onto side jambs by pressing the plastic barb into the grooves in the side jamb. Lightly tap with a mallet until the stop is tight against the side jamb.
- D) Spray low-expansion foam on both sides and head of window in between existing and replacement windows. (Fig. 22) **Note: Do not apply low-expansion foam to sill.**

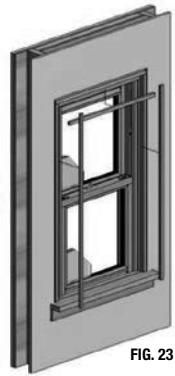
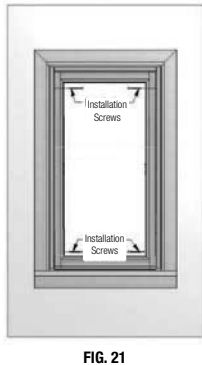
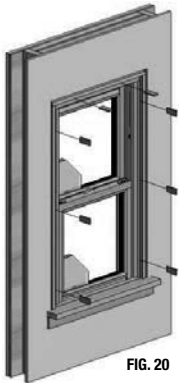
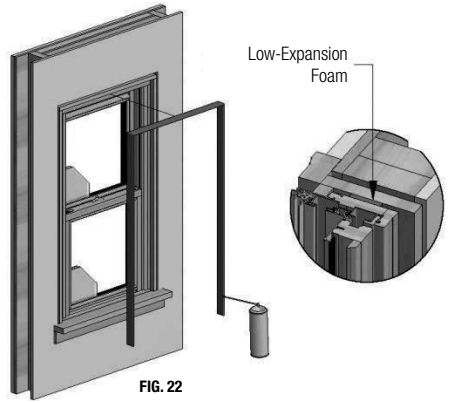
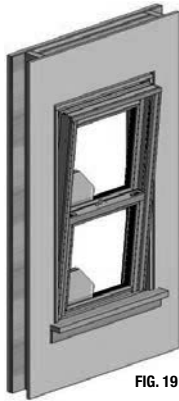

- E) Once the foam is cured, re-apply interior stops. (Fig. 23)
- F) Re-apply interior trim. (Fig. 24)
- G) Apply exterior grade sealant along the head and sides of the replacement window; sealing the gap between the existing exterior stop and replacement frame. (Fig. 25)
- H) Using a table saw, rip down the frame expanders to the appropriate width leaving approximately 0"-1/32" gap between the frame expander and the existing brickmould.

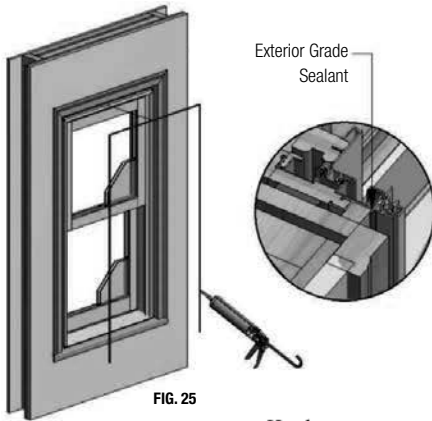

- I) Cut frame expander to the appropriate size.  
**Note: Make sure to apply frame expanders as shown in the diagram. (Fig. 26)**

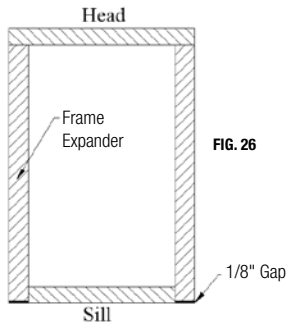

- J) Using a mallet, apply frame expander to all four sides of the window. (Fig. 27)

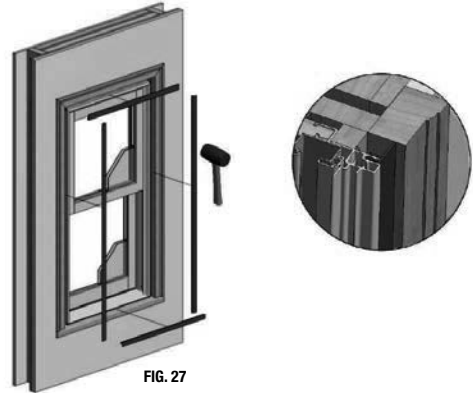

- K) Using an exterior grade sealant, apply approximately 3/16" bead of silicone between the frame expander and the brickmould for both sides and head of window. **Note: Do not apply sealant to sill.** (Fig. 28)

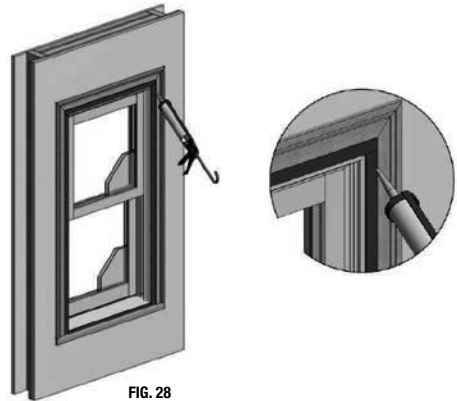



## Step 3B: Exterior Install

- A) Tilt top of replacement window toward interior as shown below. (Fig. 29)
- Insert replacement window into existing frame so top of window presses against the interior head stop.
  - Insert bottom of replacement window into frame until replacement interior stops are pressed against current interior stops.

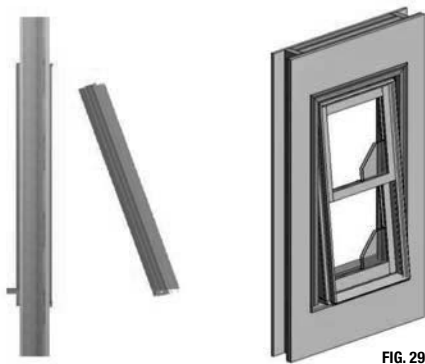

- B) Appropriately shim the window to obtain a level and square window with uniform frame dimensions. **Note: Place a shim behind each installation screw hole and at the center on each side.** (Fig. 30)
- C) Apply installation screws in pre-drilled locations in each side jamb for double hung (Fig. 31) and casement (Fig.21).

### Double hung:

- Apply each upper side screw within the interior balance channel. **Note: Ensure screw heads are flush with face of jambliner shell.**
- Raise the lower sash a minimum of six inches.
- Apply each lower side screw within the interior balance channel. **Note: Ensure screw heads are flush with face of jambliner shell.**

### Casement:

- Apply four screws into the pre-drilled holes in the side jamb. **Note: Ensure screw heads are flush with face of the side jamb.**
- Apply wood side stops onto side jambs by pressing the plastic barb into the grooves in the side jamb. Lightly tap with a mallet until the stop is tight against the side jamb.

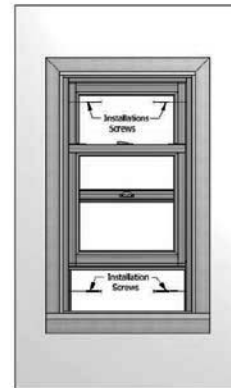
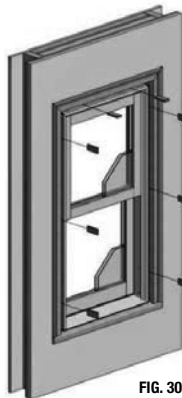

## Step 3B: Exterior Install (continued)

- D) From the exterior, spray low-expansion foam to both sides and head of window in between existing and replacement windows. (Fig. 32 & 33) **Note: Do not apply low-expansion foam to sill.**
- E) After low-expansion foam has cured, apply backer rod to both sides and head of window between the replacement and existing frame. (Fig. 32 & 33)
- F) Apply exterior grade sealant to both sides and head of window between the replacement and existing frame. (Fig. 32 & 33) **Note: Do not apply sealant to sill.**
- G) Using a table saw, rip down the frame expanders to the appropriate width leaving approximately 0"-1/32" gap between the frame expander and the existing brickmould.

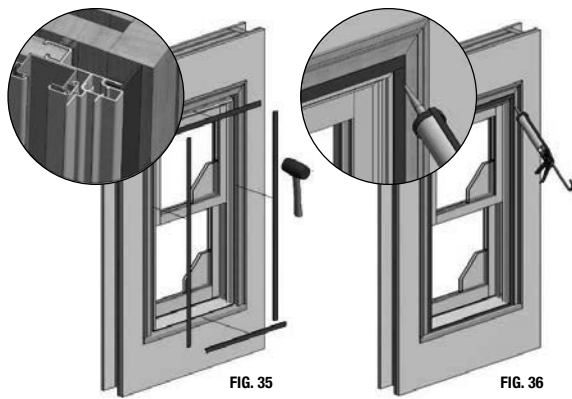
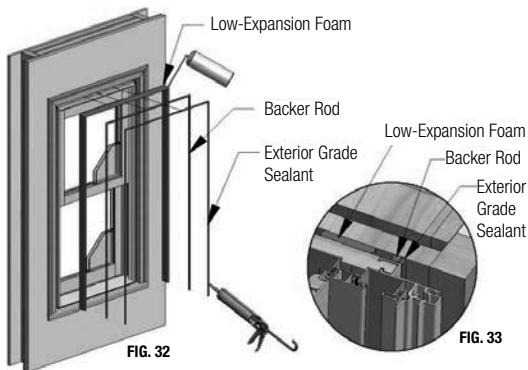

- H) Cut frame expander to the appropriate size. (Fig. 34)  
**Note: Make sure to apply frame expanders as shown in the diagram below.**
- I) Using a mallet, apply frame expander to all four sides of the window. (Fig. 35)
- J) Using an exterior grade sealant, apply approximately 3/16" bead of silicone between the frame expander and the brickmould for both sides and head of window. (Fig. 36) **Note: Do not apply sealant to sill.**

## Step 4: Completing the Installation

- A) Remove all labels or shipping materials.
- B) Operate window to ensure proper operation. The sash will not operate correctly if the window frame is out of square, over-shimmed or over-insulated.
- C) Properly finish all interior wood components within 60 days of installation. See the Care and Use Guide at [www.windsorwindows.com](http://www.windsorwindows.com) for further details on finishing wood windows.
- D) **IMPORTANT:** Do not stain or paint any hardware or vinyl components.

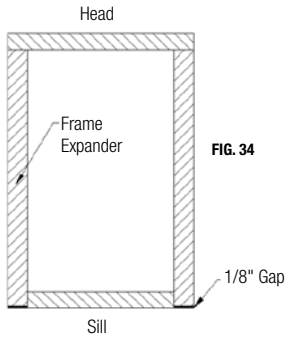

**CAUTION! READ BELOW BEFORE PAINTING**  
**When painting cellular PVC products with darker paint colors (L values of 56 or below) UV irradiance can generate high localized temperatures in the product.**

**WARNING:** Painting of any cellular PVC surface with a paint color darker than L value of 56 (where black = 0 and white = 100) will forfeit the product warranty.

If you should, despite the above warning, choose to use darker colors for cellular PVC paint, a paint specifically designed for these applications **MUST** be used. Contact the paint manufacturer to verify the paint's reflective properties and the suitability for painting cellular PVC.

Failure to maintain proper adjustment of casement windows can adversely impact the performance of your windows and may void your warranty.

**Caseмент Windows Operating Sash Adjustment:** The sashes of Casement Operating Windows must be adjusted to ensure proper operation and performance. The sashes must be adjusted so the gap between the sash and the frame is consistent. The width of the gaps on the left and right should be similar. The width of the gaps on the top and bottom should be similar. All the gaps should be uniformly straight from one end to another. If you have questions, please see Windsor's Care and Use Guide at [www.windsorwindows.com/support/service-information](http://www.windsorwindows.com/support/service-information). **CAUTION: Misaligned sash will result in a misaligned seal which will adversely affect the performance of the window. As a result, the failure to maintain proper sash adjustment will void Windsor's warranty.**

To adjust the casement sash, first fully open the window. Next, slip the adjustment wrench (Windsor part number 540036) onto the base of the stud, found between the support arm and the track of the lower hinge. Swinging the wrench away from the lock side of the window will decrease the amount of sash drag.

The maximum adjustment is reached when the stud flats are parallel to the track. Note: Turning the stud flats beyond parallel will not increase adjustment. For even more adjustment, a similar procedure can be used on the upper hinge. Upper hinge adjustment is made by swinging the wrench toward the lock side of the window. Maximum adjustment is obtained when the stud flats are parallel to the track.

Stud may be adjusted with 3/8" or 7/16" wrench if support arm is removed before adjustment. (Fig. 37)

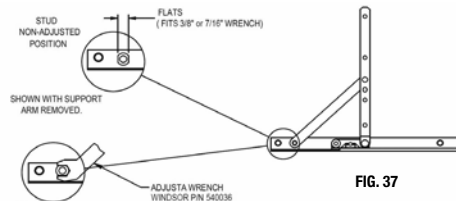

FIG. 37

If you have any questions regarding your Windsor Windows, please contact Windsor Windows & Doors directly at 1-800-218-6186. Or you can visit us online at [www.windsorwindows.com](http://www.windsorwindows.com), where you will find helpful information as well as our Care and Use Guides, which will assist you in preserving your windows and patio doors. While you are at our site, you can also complete and submit the form on the Contact page, and one of our window specialists will promptly answer your question.

## Window Opening Control Device

Please check applicable building codes to determine whether a window opening control device is required.

## Care and Use

For information about the care and use of your Windsor products, please visit the [www.windsorwindows.com/support](http://www.windsorwindows.com/support), and click "Warranty, Care & Installation," where you will find a link to our Care and Use Guide. Or contact your local independent Windsor distributor and ask for a copy of the Care and Use Guide, which contains information on finishing, cleaning, what to look for during yearly inspections, general maintenance tips, sash/panel adjustment, sash/panel removal, screen removal and information on condensation. You should inspect your windows at least annually.

## Warranties

You can find a copy of our current Warranty at the website, under the "Support" tab. If you have Windsor products that are older, please contact Windsor at 1-800-218-6186, and we will provide a copy of the applicable warranty.

